

GENERAL TOLERANCES	DIMENSION	>1	>30	>120	>315	>1000	>2000
	MACHINING	±0.2	±0.3	±0.5	±0.8	±1.2	±2
	SHEET METAL WORK / WELDING	±0.5	±0.8	±1	±2	±3	±4

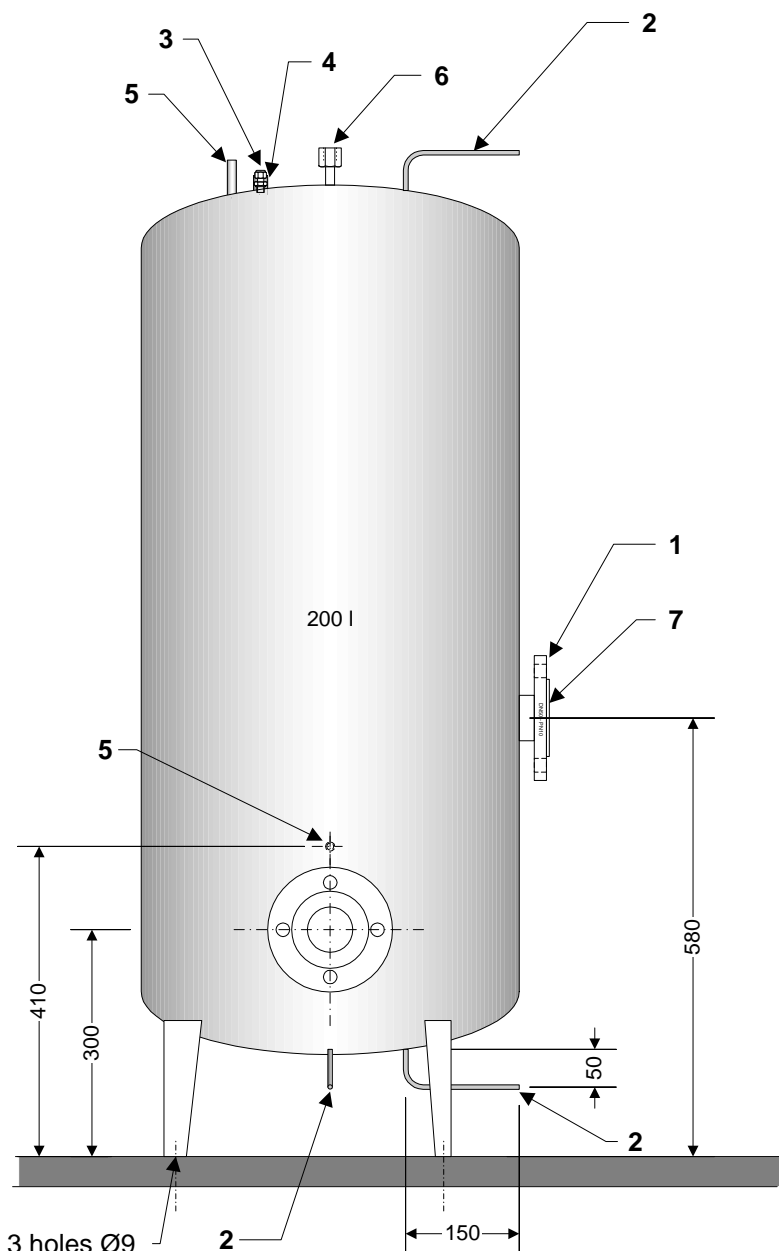

TANK 200 liters  
 ALL PARTS IN STAINLESS STEEL  
 OPERATING PRESSURE -0.5 / + 3 bars  
 OPERATING TEMPERATURE -20 / + 20 °C

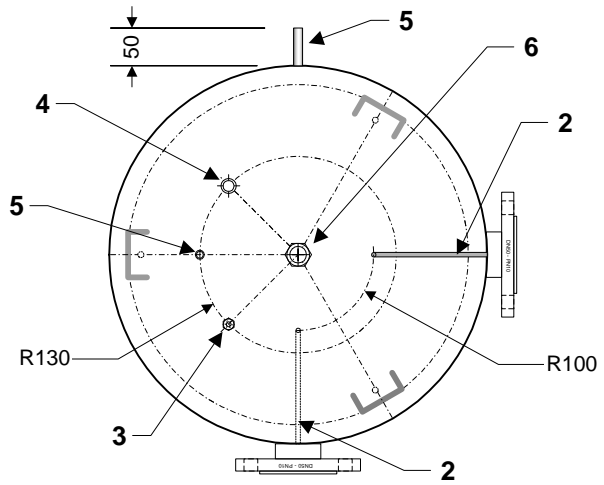

7	2	41.01.80.350.1	WELDABLE COLLAR DN50 - 316L
6	1	41.38.20.540.4	ADAPTER FEMALE Ø12X1/2"NPT
5	2	39.36.05.430.6	ROUND TUBE 316L Ø10/12
4	1	41.08.28.104.9	STRAIGHT SOCKET 1/4"
3	1	41.40.03.113.8	SAGANA FERRULE UNION 1/4X6mm
2	3	39.36.05.430.6	ROUND TUBE 316L Ø4/6
1	2	41.01.78.550.8	ISO ROTABLE FLANGE DN50 - PN10

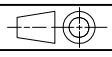
ITEM	QTY.	PART NO.	DESCRIPTION
ATLAS - EVAPORATIVE SYSTEM			BONNEAU - P
<b>PHASE II - 1/8 FULL SCALE BUFFER TANK 200 I - SPEC.</b>			
			SCALE 1:10
			12/10/2000
CERN/EST/SM/SF			186.7.08

